

# *A new type of organic electrosynthesis reactor with a two-phase gas-electrolyte stream flowing through a mercury cathode. I. Application in electrochemical preparation of organotin compounds*

A. SAVALL

*Laboratoire de Chimie-Physique et Electrochimie, Associé au CNRS, Université Paul-Sabatier, 118 route de Narbonne, 31077 Toulouse, France*

G. LACOSTE

*Laboratoire de Recherche et Développement en Génie Chimique, Associé au CNRS, Institut du Génie Chimique, Chemin de la Loge, 31078 Toulouse, France*

P. MAZEROLLES

*Laboratoire des Organométalliques, Equipe de Recherche Associée au CNRS, Université Paul-Sabatier, 118 route de Narbonne, 31077 Toulouse, France*

Received 17 March 1980

---

An electrochemical technique is particularly convenient for the synthesis of hexabutyl-distannane and hexaphenyl-distannane. The reaction involved is the reduction of compounds of the type  $R_3SnX$  dissolved in methanol. The conditions for preparative electrolysis were determined from a preliminary study of electrochemical kinetics. The technique employed permits continuous electropreparation and separation of these distannanes. In the reactor, an efficient renewal of the cathodic surface is obtained by passing the electrolytic solution, together with bubbled nitrogen, through the mercury pool. Results of electropreparation of distannanes in a large laboratory-scale apparatus are presented.

---

## **1. Introduction**

In some electrochemical syntheses for producing organic compounds, mercury is a particularly convenient cathode material because of its unique properties, namely a high hydrogen overvoltage, a catalytic effect which determines the reaction product and a clean and reproducible surface. Thus a large number of cell designs have been proposed for carrying out laboratory electrolyses of organic compounds with a mercury cathode [1], but very few large-scale cells have been described [2]. The designs of all these cells generally include a continuously renewable cathode surface. This had been achieved by (a) stirring or (b) circulating the mercury. The former technique is suitable for a laboratory cell in which the surface

of a mercury pool is renewed by stirring with an X-shaped, teflon-coated, magnetic stirrer [3]. The latter, which has been proposed for a large-scale electrolyser [4], gives a compact design with a spirally convolute channel along which mercury circulates continuously. An electrolyser with a shelf-type mercury cathode suitable for reducing organic compounds has also been described [5]. The problem with such systems lies in the use of mercury pumps or mechanical stirring.

Furthermore, all practical applications of electrolysis in organic synthesis necessarily require continuous flow operation [6]. Electrolysis with a circulating solution is a possible mode of operation which simultaneously solves the problems of mass transfer, renewal of the surface of the mercury pool and also, in some cases, removal of the final

product [7, 8]. Indeed, if the electrolytic solution flows through the mercury pool, it is possible to solve all of these problems.

The purpose of this study was to develop and test this type of electrode in an electrochemical reactor, simple in design, using standard laboratory material wherever possible. The electrosynthesis unit described here was used to show the validity of the electrochemical preparation of some organotin compounds.

Organotin compounds have found widely scattered applications in various fields because of their use as stabilizers of polyvinylchloride, as fungicides, catalysts and anticorrosive agents [9, 10]. The principal category of industrial tin compounds comprises the mononuclear derivatives  $R_{4-n}SnX_n$ ; the dinuclear tin derivatives such as  $R_3SnSnR_3$  have found far fewer applications [9, 10], probably because of the high cost of their production by traditional methods. Therefore, the search for new and simple methods of synthesising them is an important matter. Analysis of previous papers [11–13], together with work performed in our laboratory, shows that electrochemical techniques are promising for distannane synthesis.

The present stage of the work is concerned with transferring the study of electrochemical kinetics to a larger-scale operation by bringing into operation a unit for continuously manufacturing distannanes at a production rate of a few hundred grams per day. Hence a reactor has been built containing a mercury cathode through which passes a two-phase stream of inert gas and electrolyte. Part 1 deals with the electrochemical preparation of hexaphenyldistannane  $Ph_3SnSnPh_3$  and hexabutyldistannane  $Bu_3SnSnBu_3$  in this new electrolysis cell, while Part 2 [14] is a study of mass transfer for different operating modes of the cell.

## 2. Preliminary study of the electrochemical system

In the first part of the present work a traditional electrochemical study into the electrode reaction has been undertaken with a view to determining the best conditions for obtaining the desired products.

### 2.1. Reduction of $R_3SnX$ compounds

The polarographic behaviour of trialkyltin compounds  $R_3SnX$  has been studied by several work-

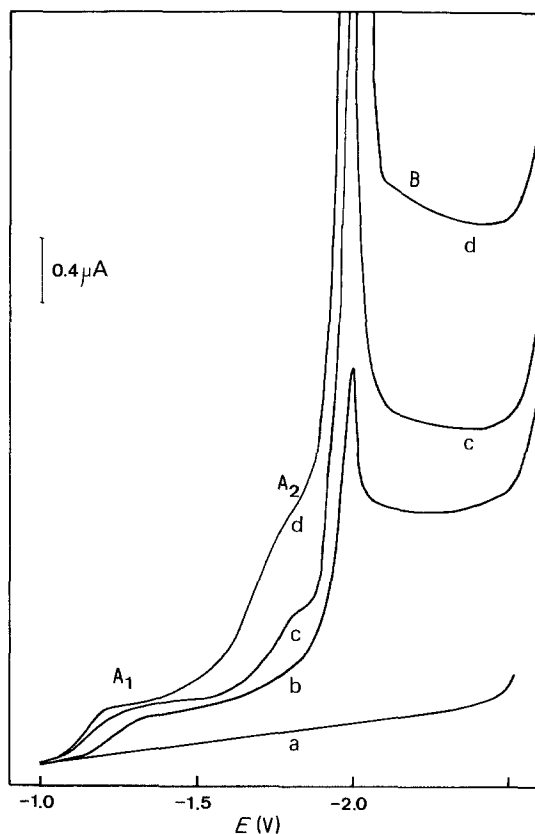
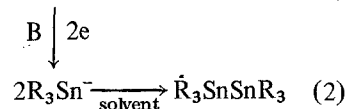
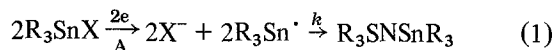

Fig. 1. D.c. polarograms of  $Ph_3SnCl$  in MeOH, 0.5 M  $LiClO_4$ . (a) residual, (b)  $7.5 \times 10^{-5} \text{ mol dm}^{-3}$   $Ph_3SnCl$ , (c)  $1.2 \times 10^{-4} \text{ mol dm}^{-3}$   $Ph_3SnCl$ , (d)  $2.3 \times 10^{-4} \text{ mol dm}^{-3}$   $Ph_3SnCl$ .

ers [12, 13, 15–19]. In a protic medium the cathodic process takes place according to the scheme proposed by Devaud [12, 13]:



We have studied the reduction of  $Ph_3SnCl$  and  $Bu_3SnCl$  in methanol by voltammetric techniques and small-scale electrolysis at controlled potential (about 5 g of reactant and  $15 \text{ cm}^2$  area mercury cathode, mechanically stirred).

Fig. 1 shows that polarographic reduction (polarograms recorded on a Metrohm E 506 polarograph) of  $Ph_3SnCl$  in MeOH involves two steps: ( $A_1 + A_2$ ) and B. The wave  $A_2$  is preceded by the appearance of an adsorption prewave  $A_1$  which indicates an adsorption of the radical  $Ph_3Sn \cdot$  on to

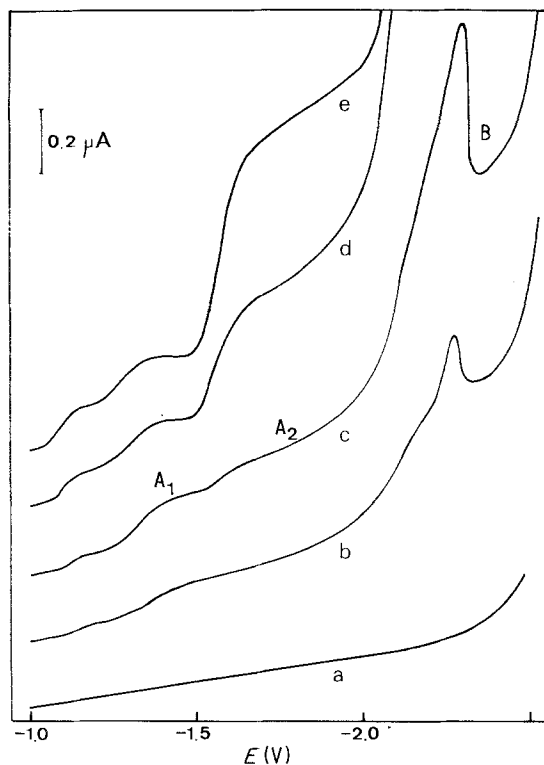

Fig. 2. D.c. polarograms of  $\text{Bu}_3\text{SnCl}$  in  $\text{MeOH}$ ,  $0.5 \text{ M LiClO}_4$ . (a) residual, (b)  $1.75 \times 10^{-4} \text{ mol dm}^{-3} \text{ Bu}_3\text{SnCl}$ , (c)  $3.46 \times 10^{-4} \text{ mol dm}^{-3} \text{ Bu}_3\text{SnCl}$ , (d)  $6 \times 10^{-4} \text{ mol dm}^{-3} \text{ Bu}_3\text{SnCl}$ , (e)  $8.46 \times 10^{-4} \text{ mol dm}^{-3} \text{ Bu}_3\text{SnCl}$ .

the mercury surface [14]. In Fig. 1 it can be seen that the currents  $i_{A_1} + i_{A_2}$  and  $i_B$  are of equal value. The first step ( $A_1 + A_2$ ) involves the formation of the radical  $\text{Ph}_3\text{Sn}^\cdot$  which forms  $\text{Ph}_3\text{SnSnPh}_3$  in a subsequent reaction. In the second step B, the radical is then reduced to form the anion  $\text{Ph}_3\text{Sn}^-$ .

Electrolysis of  $\text{Ph}_3\text{SnCl}$  in  $\text{MeOH}$ ,  $0.5 \text{ M LiClO}_4$  (or  $\text{LiCl}$ ) conducted at controlled potential on the plateau of the first wave ( $-1.8 \text{ V}$  with respect to  $\text{Ag}/\text{Ag}^+$ ) gives hexaphenyldistannane. The same product is also obtained by electrolysis at the second wave B ( $-2.2 \text{ V}$  with respect to  $\text{Ag}/\text{Ag}^+$ ), in agreement with Devaud's reaction scheme shown above. So, for these electrosyntheses, the choice of the value for the mercury electrode potential is not a critical parameter in the preparative electrolysis of  $\text{Ph}_3\text{SnSnPh}_3$ .

Fig. 2 shows typical polarograms of  $\text{Bu}_3\text{SnCl}$  in methanol. The first wave A is split into several steps and the behaviour of its limiting current  $i_{A_2}$  ( $-1.8 \text{ V}$ ) is characteristic of an electrode pro-

cess in which an insoluble, insulating film is formed on the electrode surface. This polarographic behaviour is confirmed by results of small-scale electrolysis operated at controlled potential on the first-wave plateau at  $-1.7 \text{ V}$ : a layer of insoluble oily liquid, which is pure hexabutyl-distannane, is rapidly formed. Electrolysis at  $-2.2 \text{ V}$  corresponding to the pseudo-plateau of the second wave B (Fig. 2) shows that hexabutyl-distannane is also the main product of the second reduction step. However, the formation of polymeric by-products shows that secondary processes occur in parallel with the second reduction step. Mehner *et al.* [15] have identified polymeric  $(\text{Bu}_2\text{Sn})_x$  and also tetrabutyltin  $\text{Bu}_4\text{Sn}$  during electrolysis conducted at the second step of the reduction of  $\text{Bu}_3\text{SnCl}$  in methanol. These authors have proposed a somewhat different, alternative pathway for the second reduction step, one involving carbanion extrusion:

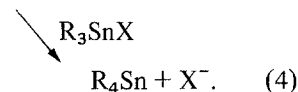
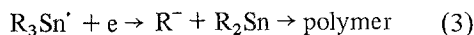

Hence, for the electropreparation of  $\text{Bu}_3\text{SnSnBu}_3$ , the working potential in  $\text{Bu}_3\text{SnCl}$  reduction has been fixed between  $-1.7$  and  $-1.9 \text{ V}$  with respect to  $\text{Ag}/\text{Ag}^+$ .

The electrochemical synthesis of these products has advantages compared with chemical methods of preparation. It uses commercially manufactured raw materials and a small number of steps. Furthermore hexaphenyldistannane and hexabutyl-distannane have very low solubilities in alcohol media, thus they are easy to separate. Keeping in mind that isolation and purification of the cell products can be a stumbling block to electrochemical synthesis [20], this latter property is also an important advantage of this process.

## 2.2. The counter-electrode reaction

The anodic reaction on the graphite electrode is the formation of the halogen. When lithium chloride is used as the supporting electrolyte the reaction is

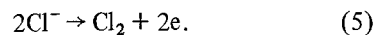

During the electrolysis the green colour of chlorine was evident in the methanolic solution of the

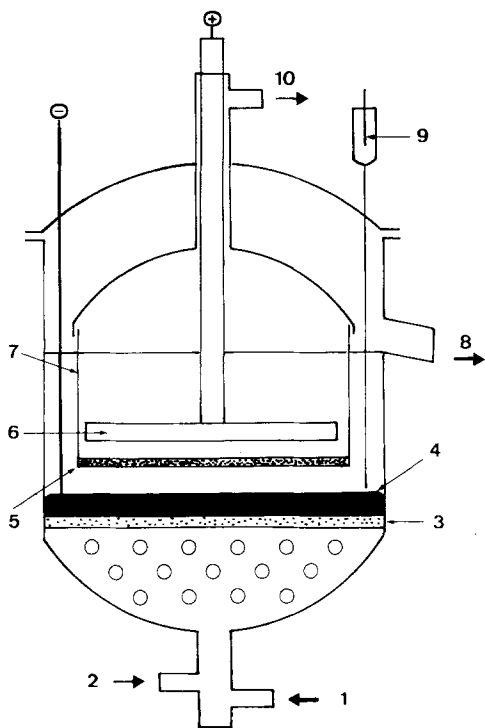

Fig. 3. Design of the electrolytic cell. 1, electrolyte in (PFR); 2, nitrogen in; 3, glass sinter (grade 0); 4, mercury cathode; 5, glass sinter (grade 4); 6, graphite anode; 7, anode compartment; 8, electrolyte out (to separator); 9, reference electrode:  $\text{Ag}/\text{Ag}^+$ ; 10, cell effluents ( $\text{Cl}_2$ ,  $\text{N}_2$ ).

anode compartment. In this work, the reaction of chlorine with methanol was not examined, but it has been recently shown [21] that during oxidation of chlorine ion on graphite in methanol, the products formed are formaldehyde and methyl formate, each with only 5% current efficiency.

### 3. Design of the apparatus for large-scale preparation

#### 3.1. Cell construction

A cross section of the cell is shown in Fig. 3. A right cylindrical glass vessel of sectional area  $80 \text{ cm}^2$  and 2 litres capacity, with an inner diameter of 10 cm, is employed. A large porosity (grade 0) glass frit is welded in the lower part of the vessel. The main feature of this cell is the unusual arrangement of the 1.2 cm thick mercury pool, which lies on the frit through which the electrolysed solutions flow. The anodic and cathodic compartments are separated by a glass frit of

low porosity (grade 4). A better separation with a lower electrical resistance would be preferred for a practical electrolyser, but was thought to be an unnecessary complication at this stage. The anode is a graphite disk (diameter 8 cm) screwed on to the anode feeder. The inner anodic compartment contains a stationary electrolyte solution. The upper part of this compartment, which can be separated from the lower part, is a glass tube which acts as a passage for the current feeder and the exhaust gases (chlorine and nitrogen). Thus the electrode gap can be varied and in this case has been fixed at 2 cm.

The cell can be connected to the inlet flow system through the base or the cover. If the electrolyte inlet is connected to the base (Fig. 3) the cell acts like a plug-flow type reactor (PFR). But when the inlet electrolyte flow is passed through the cover the electrolyser works as a continuously stirred reactor (CSR) [14]. In these two cases, a jet of nitrogen gas entering the cathode compartment through the cathodic pool improves the renewal of the mercury surface and the removal of the insoluble reaction product. In long-term operations such as those described here, the plug-flow mode was preferred. Reasons for this choice will be discussed in Part 2 [14].

#### 3.2. Flow circuit

The assembly of the flow system is shown in Figs. 4 and 5. In an external loop, a pump (polypropylene pump with a maximum flow rate of  $45 \text{ l h}^{-1}$ ) recirculates the electrolyte. The auxiliary equipment for continuous production was chosen to suit the physical state of the product synthesized: a liquid cyclone combined with a filtration system in the case of the solid hexaphenyldistannane (Fig. 4); a settler-decanter in the case of hexabutyl-distannane, a liquid denser than methanol (Fig. 5).

#### 3.3. Electric circuit

The power source is a potentiostat (Tacussel, PRT 40-5) capable of delivering a maximum of 5 A under 40 V. A linear sweep potential generator (Tacussel, Servovit) and an integrator (Tacussel, IG5N) were also used with an X-Y recorder. The electrolysis potential is controlled against an  $\text{Ag}/\text{Ag}^+$  reference electrode.

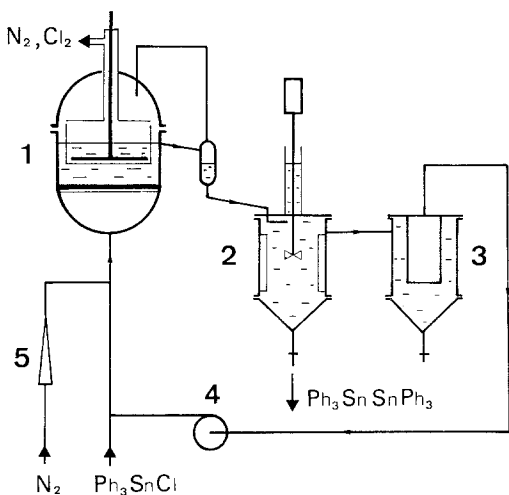

Fig. 4. Continuous electropreparation of hexaphenyldistannane. 1, electrolyser (PFR); 2, liquid cyclone; 3, filter; 4, pump; 5, rotameter.

#### 4. Results and discussion of preparative electrolysis

The runs were made continuously at room temperature in the PFR and the electrolysed solutions (3 to 5 litres) were recycled through the reactor.

##### 4.1. Preparation of hexaphenyldistannane

The reduction of triphenyltin chloride is performed in MeOH, 0.5 M LiClO<sub>4</sub> (or LiCl) flowing at

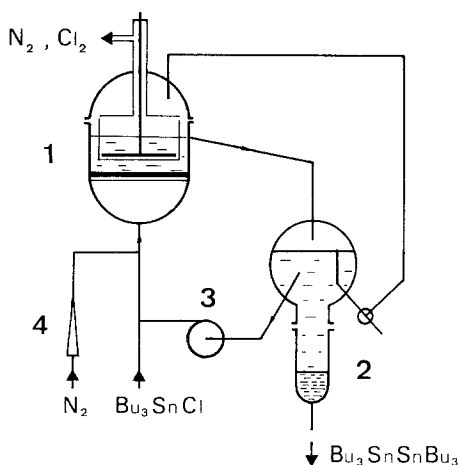
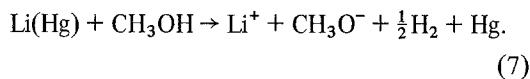
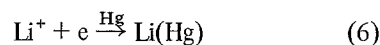

Fig. 5. Continuous electropreparation of hexabutyl-distannane. 1, electrolyser (PFR); 2, separator; 3, pump; 4, rotameter.

36.41 h<sup>-1</sup>. The nitrogen flow rate is 1061 h<sup>-1</sup>. With these operating conditions the limiting current observed at a controlled potential of -2.2 V is 3.6 A as long as the reactant concentration is higher than 3.9 × 10<sup>-2</sup> mol dm<sup>-3</sup> (15 g l<sup>-1</sup>) and the cell voltage is 40 V. These conditions correspond to a maximum production rate, which can be evaluated as 1 kg/day if the mean value of the current efficiency is taken into account (see Table 1).

At the beginning of the electrolysis conducted at -1.8 V, the solution takes on a yellow-orange colour. This could be explained by the formation of the Ph<sub>3</sub>Sn<sup>•</sup> radical, as this change in colour is observed after a few minutes in the whole installation. But if the working potential is more negative than -2.2 V, a greyish colour appears rapidly. This colour can be attributed to the formation of colloidal mercury [22] according to the scheme



The range of operating conditions and performances are summarized in Table 1. From five experiments, of 6 to 8 hours duration, the mean values of the current efficiency and the material yield were determined as 90 and 95% respectively. The material yield value is higher than any hitherto reported by classical methods [9, 10, 23]. The current efficiency value, lower than unity, can be explained by considering firstly the electrochemical reduction of Li<sup>+</sup> which may occur on the crests of the waves on the mercury surface, i.e. the points having the highest value of overpotential, and secondly the reduction of the reactant reformed by chemical reaction between the distannane and the chlorine which has diffused through the imperfect glass diaphragm.

A recrystallization of the crude product in benzene gives pure, white hexaphenyldistannane (*T<sub>F</sub>* = 235–7° C). Results of the elementary analysis of the product are given in Table 2.

##### 4.2. Preparation of hexabutyl-distannane

For the production of Bu<sub>3</sub>SnSnBu<sub>3</sub> from a solution of Bu<sub>3</sub>SnCl in MeOH, 0.5 M LiCl, the cell was used with a flow rate of 47.51 h<sup>-1</sup> and a 1061 h<sup>-1</sup>

Table 1. Electropreparation of distannanes

	$Ph_3SnCl$	$Bu_3SnCl$
Electrolyte (0.5 M)	$LiClO_4$ (or $LiCl$ )	$LiCl$
Initial concentration ( $mol\ dm^{-3}$ )	$3.9 \times 10^{-2}$	0.12
MeOH flow rate ( $m^3\ s^{-1}$ )	$1.01 \times 10^{-5}$	$1.32 \times 10^{-5}$
$N_2$ flow rate ( $m^3\ s^{-1}$ )	$2.94 \times 10^{-5}$	$2.94 \times 10^{-5}$
Working potential (V w.r.t. $Ag/Ag^+$ )	-2.2	-1.9
Current (A)	3.6	1.9
Voltage (V)	40	20
Maximum production rate* (kg/day)	1	0.3
Current efficiency (%)	90	61
Electrolysis energy ( $kWh\ kg^{-1}$ )	3.5	3
Pumping energy ( $kWh\ kg^{-1}$ )	1	3
Material yield (%) <sup>†</sup>	95	70
Product	$Ph_3SnSnPh_3$	$Bu_3SnSnBu_3$

\* Calculated for the initial concentration of the reactant.

<sup>†</sup> A complete electrolysis would have been too long [7], so runs were generally stopped after 6 to 8 hours and the quantities of unchanged reactant determined by polarography.

flow rate of nitrogen through mercury. These hydrodynamic conditions are necessary to maintain a continuous elimination of the thin, grey, liquid film formed on the mercury surface. For the electrolysis of a  $Bu_3SnCl$   $0.12\ mol\ dm^{-3}$  solution, at a working potential of  $-1.9\ V$ , the current is  $1.9\ A$  and the cell voltage  $20\ V$ . The value of the material yield (Table 1), calculated on the basis of five runs of 6 to 8 hours, shows that the main product of the reaction is hexabutyldistannane. The material yield increases from 70% at  $-1.9\ V$  to 80% at  $-1.7\ V$ . As was pointed out by Mehner *et al.* [15] the explanation of this lower material yield can be found in the formation of polymeric tin compounds and tetrabutyltin (Reactions 3 and 4), but no attempt has been made in this work to analyse the by-products formed.

Because of the relatively low material yield (70%), the current efficiency calculated on the basis of the weight of the distannane formed is only 61% (run at  $-1.9\ V$ ; Table 1). The liquid product must be filtered; it then presents these

Table 2. Results of analysis of hexaphenyldistannane

Element	Percentage found	Percentage calculated
Carbon	61.49	61.77
Hydrogen	4.26	4.32
Tin	33.87	33.91

characteristics for a typical run conducted at  $-1.7\ V$ :

$$n_{\text{found}}^{20} = 1.5145, \quad n_{\text{lit}}^{20} = 1.5132 [24].$$

Results of analysis are given in Table 3.

#### 4.3. Energy consumption

On the basis of the above conditions, the electrolysis energy consumption is about  $3\ kWh\ kg^{-1}$  of  $Bu_3SnSnBu_3$  and  $3.5\ kWh\ kg^{-1}$  of  $Ph_3SnSnPh_3$ . The main component in the total cell voltage is the ohmic drop through the cell due to its internal resistance (about 90%) and in the present case, the major energy loss results from the use of a high resistance glass frit separator.

On the other hand, the theoretical pumping energy to ensure the circulation of the electrolyte and the gas through the glass frit (grade 0), the mercury pool and the electrolyte layer is small (about one hundred times less than the electrolysis

Table 3. Results of analysis of hexabutyldistannane

Element	Percentage found	Percentage calculated
Carbon	49.60	49.70
Hydrogen	9.25	9.38
Tin	40.96	40.92

energy). In actual fact, the reciprocating pump used in the experiments consumed about 1 kWh per day. Therefore, in this electrochemical process, the total energy consumption is not a decisive factor in manufacturing cost when compared with the high value of the final products.

#### 4.4. Loss and removal of mercury

Mercury pollution is a topical problem in view of its potential hazard, but it must be kept in mind that organotin compounds are also generally very toxic [9]. Handling these products requires strict laboratory practice. One cause of the loss of mercury is its mechanical entrainment. Sometimes, particles of the tin compound formed may escape from the cathode, carrying over fine droplets of mercury from the cell. The quantity of mercury entrained is always small: about one gram per day from a batch of 1200 g. This effect, however, is not at all serious since the mercury is entirely recoverable during the recrystallization or the filtration of the crude product.

Another loss can occur due to dissolution of metallic mercury in the solvent. This loss is very limited, firstly because the solubility of mercury in methanol is low (about  $1 \text{ mg l}^{-1}$  at  $20^\circ \text{C}$  [25]) and secondly because the volume of electrolytic solution is continuously recycled through the reactor. Waste solution treatments recently developed for the removal of mercury by polymeric-mercaptan resin [26] are able to solve this pollution problem.

#### 5. Conclusion

Based on the results obtained in small-scale laboratory tests, the reduction of compounds of  $\text{R}_3\text{SnX}$  type was carried out in a large laboratory-scale apparatus with the aim of examining the feasibility of the process. Electrochemical synthesis of compounds  $\text{R}_3\text{SnSnR}_3$  by reduction of  $\text{R}_3\text{SnCl}$  has been performed in methanol solution. Electrolysis was conducted in a new type of divided cell with the electrolyte flowing through a mercury-pool cathode together with an inert gas stream. The following advantages have been demonstrated:

(a) Yields of 95% with  $\text{R} = \text{Ph}$  and 80% with  $\text{R} = \text{Bu}$  are obtained. The energy consumption is about  $3 \text{ kWh kg}^{-1}$  of product for the electrolysis.

(b) The cell design is simple and needs no mechanical stirring.

(c) The work-up of the products is easy because of their insolubility in the medium.

(d) Continuous operation is possible.

The question of mass transport to the mercury-solution interface in this type of reactor is dealt with in Part 2.

#### Acknowledgements

We are grateful for financial support from the Délégation Générale à la Recherche Scientifique et Technique (Contract 75-7-1550).

#### References

- [1] M. M. Baizer, 'Organic Electrochemistry', M. Dekker, New York (1973) Ch. 4.
- [2] A. P. Tomilov and M. Ya Fioshin, *Brit. Chem. Eng.* 16 (1971) 154.
- [3] C. Moinet and D. Peltier, *Bull. Soc. Chim. France* (1969) 690.
- [4] I. G. Shcherbakov, *Izvest. Uralsk. Politekh. Inst.* 3 (1922-3) 83.
- [5] M. S. V. Pathy, *Electrochem. Technol.* 3 (1965) 94.
- [6] R. E. Sioda, *Electrochim. Acta* 19 (1974) 57.
- [7] A. Savall and G. Lacoste, *Proc. 1st Mediterranean Congress on Chemical Engineering, Barcelona, November (1978)*.
- [8] *Idem, Proc. 6th Int. Symp. on Chemical Reaction Engineering, Nice, March (1980)*.
- [9] R. C. Poller, 'The Chemistry of Organotin Compounds', Logos Press, London (1970) Ch. 15.
- [10] A. K. Sawyer, 'Organotin Compounds' Vol. 3, M. Dekker, New York (1972) Ch. 12.
- [11] L. Riccoboni, *Atti Ist. Veneto Sci.* II 96 (1937) 183.
- [12] M. Devaud, *J. Chim. Phys.* 63 (1966) 1335.
- [13] M. Devaud and Y. Le Moullec, *Electrochim. Acta* 21 (1976) 395.
- [14] A. Savall, J. Mahenc and G. Lacoste, *J. Appl. Electrochem.* 11 (1981) 69.
- [15] H. Mehner, H. Jehring and H. Kriegsmann, *J. Organometall. Chem.* 15 (1968) 107.
- [16] M. D. Booth and B. Fleet, *Anal. Chem.* 42 (1970) 825.
- [17] B. Fleet and N. B. Fouzder, *J. Electroanal. Chem.* 63 (1975) 59.
- [18] G. Costa, *Gazz. Chim. Ital.* 80 (1950) 42.
- [19] Yu. M. Tyurin and V. N. Flerov, *Elektrokhim.* 6 (1970) 1548.
- [20] R. B. MacMullin, *Electrochem. Technol.* 2 (1964) 106.
- [21] D. A. White and J. P. Coleman, *J. Electrochem. Soc.* 125 (1978) 1401.
- [22] R. G. Barradas, O. Kutowy and D. W. Shoosmith, *Electrochim. Acta* 19 (1974) 49.
- [23] M. Dub, 'Organometallic Compounds, Vol. 2: Compounds of Germanium, Tin and Lead',

- 
- (edited by R. W. Weiss) Springer-Verlag, Berlin (1967).
- [24] W. P. Neumann, B. Schneider and R. Sommer, *Liebigs Ann. Chem.* 692 (1966) 1.
- [25] P. Pascal, 'Nouveau Traité de Chimie Minérale', Vol. 4, Masson, Paris (1962) p. 509.
- [26] G. J. de Jong and C. N. J. Rekers, *Proc. 1st World Mercury Congress, Barcelona*, Vol. 1, May (1974) p. 377.